



LE DÉSEMBOUEUR FICHE TECHNIQUE

Référence

DS-i65



Ø nominal	DN65	Ø du raccordement	2"1/2
Longueur totale	255 mm	Type de raccordement	Bride PN16 Ø 185 mm
Ø extérieur du corps	110 mm	Orifices sur la bride	8 orifices de Ø 18 mm
Poids	14 kg	Entraxe entre les orifices	145 mm

Température
maximale **155°C**

Pression maximale
25 bars



Matière du corps
INOX 316L

Température
minimale **-20°C**

Capacité
de traitement maximale
8,06 l/s soit 29 m³/h

Pertes de charge
à débit maximal : **110 mbar**

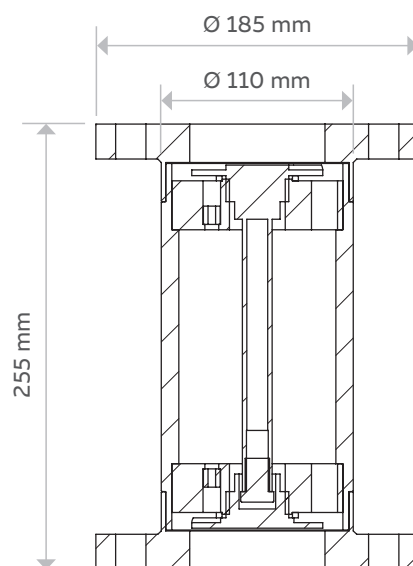
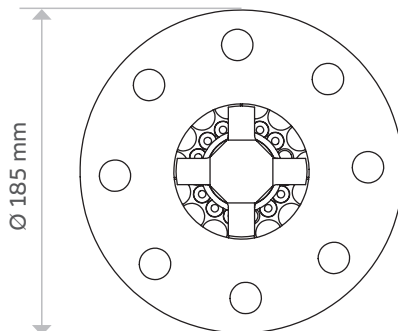
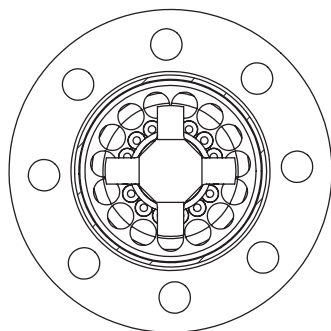
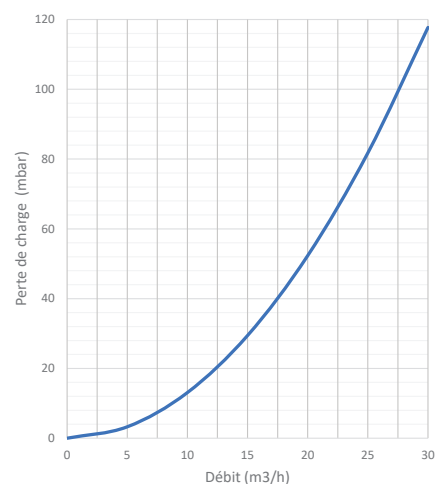

GAMME DÉSEMBOUEUR